

LA--11816-MS

DE91 002399

*Bidirectional Slapper Detonators  
in Spherical Explosion Systems*

*Ernest C. Martinez*



**MASTER**

DISTRIBUTION OF THIS DOCUMENT IS UNLIMITED <sup>st</sup>

Los Alamos National Laboratory  
Los Alamos, New Mexico 87545

DISTRIBUTION OF THIS DOCUMENT IS UNLIMITED

# **BIDIRECTIONAL SLAPPER DETONATORS IN SPHERICAL EXPLOSION SYSTEMS**

by

**Ernest C. Martinez**

## **ABSTRACT**

**A bidirectional "slapper detonator" has been proven effective for producing a spherically expanding shock wave. Two bridge foils are used to propel flyers in opposite directions, thereby initiating two explosive pellets, each embedded in one hemisphere of a spherical system. This detonation system produces a nearly perfect spherically expanding detonation front.**

---

## **I. BACKGROUND**

The Air Force Weapons Laboratory (AFWL) has been working with the Denver Research Institute (DRI) on a program that requires the production of a spherically expanding shock wave. In an attempt to produce such a shock, AFWL has been using Reynolds Industries' RP-2 detonators embedded in spherical charges. However, that system has been found to fire asymmetrically because of the unidirectional nature of the RP-2 detonator. To solve this problem, Los Alamos National Laboratory (LANL) proposed using a bidirectional slapper detonator system to improve the symmetry of the explosion.

Bidirectional slapper detonators are simply back-to-back slapper circuits. The bidirectional slapper/cable assembly called the ER-347 was developed at LANL. Construction of the ER-347 and use of the device to initiate a spherical charge are described in LANL report LA-9283-MS (October 1982). Thus, the current program required little development work and was primarily a design, construction, and characterization exercise.

## **II. TASK DESCRIPTION**

The objective of the LANL program was to fabricate and characterize a bidirectional slapper system that will readily initiate spherical charges made up of the explosive compound PBX-9501. As an adjunct to this work, we conducted experiments with the RP-2 detonator system for comparison purposes and to see whether that system might be improved if the detonator were positioned slightly away from the equator of the sphere, which would move the center of initiation away from the geometrical center of the charge.

Characterization of the system included 1) test-firing the slapper/cable assemblies using only pellets of the explosive compound pentaerythritol tetranitrate (PETN); 2) fabricating and testing small spherical explosive assemblies, using both slappers and RP-2 detonators as initiators, for the purpose of obtaining a composite map of the break-out pattern; and 3) making 8-lb spherical assemblies, mapping the break-out pattern, and, if the assemblies were judged acceptable, shipping three of them for test-firing at DRI.

### III. BIDIRECTIONAL SLAPPER/CABLE ASSEMBLY (ER-347)

Figure 1 shows the design of the ER-347 bridge circuit. The slapper circuit is etched from ~4.6- $\mu\text{m}$  Microclad copper on 50.8- $\mu\text{m}$ -thick Kapton. The slapper/cable assembly is made up of two bridges in series, placed back to back so that the slappers are propelled in opposite directions to initiate the explosive pellets. Figure 2 shows how the

circuit is folded on itself around an insulating film. For best performance, it is essential that the bridges be as perfectly aligned with each other as possible. One hundred ER-347 cables were fabricated and measured for proper alignment. We selected fifty of these to be used in the tests.

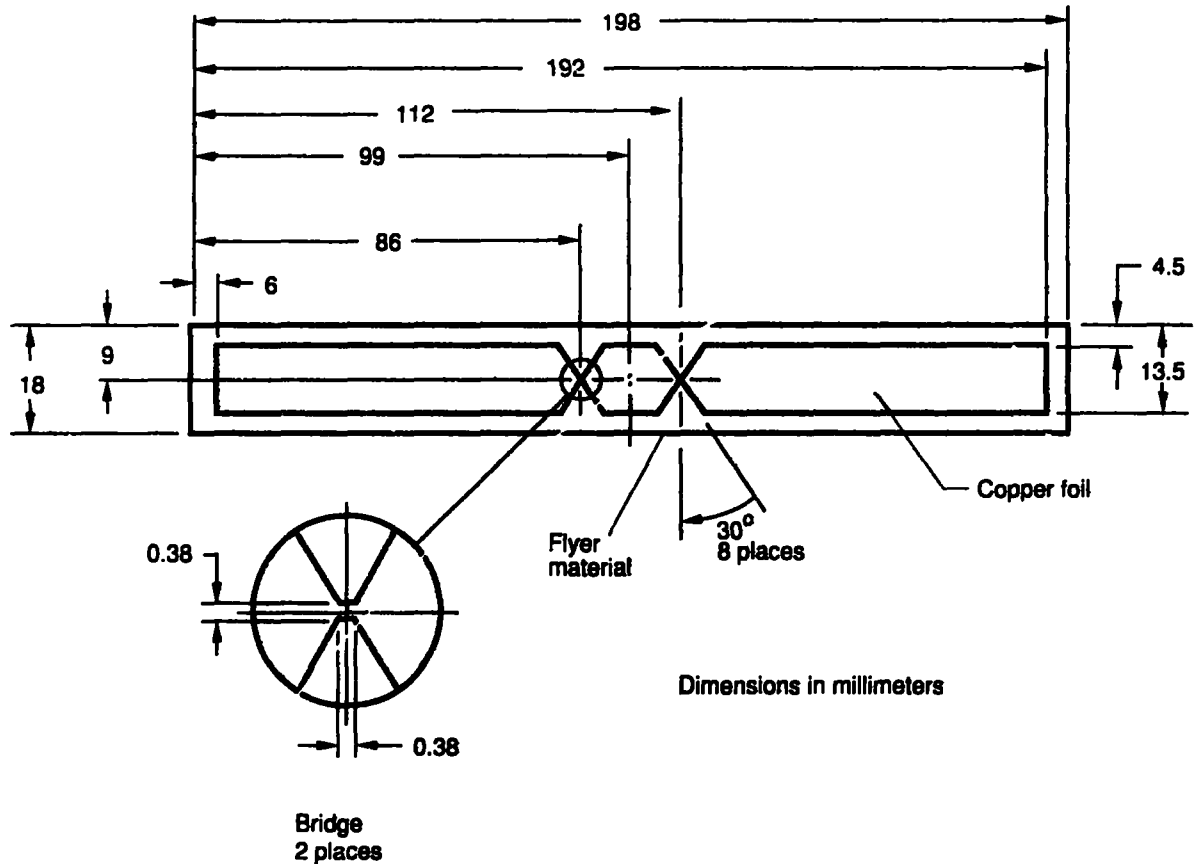

Fig. 1. ER-347 bridge circuit.

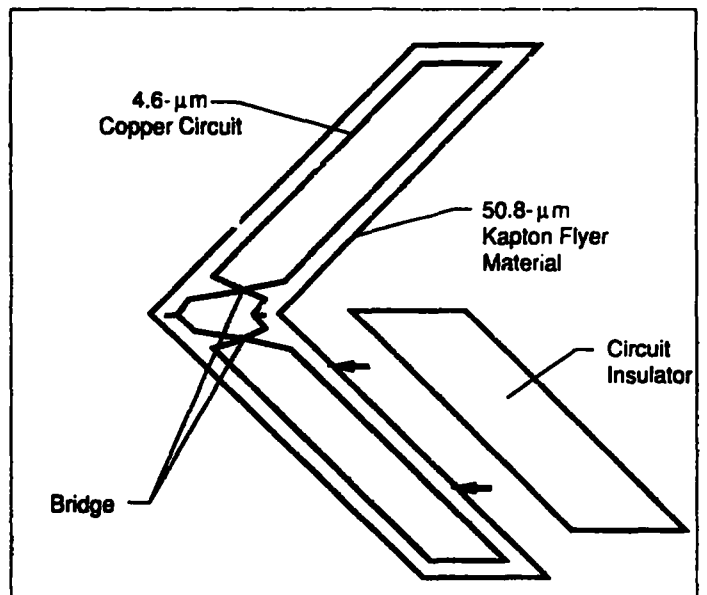

Fig. 2. ER-347 slapper circuit construction.

## IV. INITIATION TESTS

### A. ER-347 with Pellets Only

Figure 3 shows the components of the bidirectional detonation system. The barrels on each side of the slapper cable help direct the Kapton flyer toward the explosive pellets, which are placed directly over the barrels. We tested these assemblies to determine 1) transit time ( $t_s$ ) vs firing voltage, 2) transit time through each pellet, and 3) the time difference ( $\Delta t_s$ ) between the two pellets. The PETN pellets used in these tests were 5.72 mm thick and 12.5 mm in diameter; pellet density was 1.65 g/cm<sup>3</sup>.

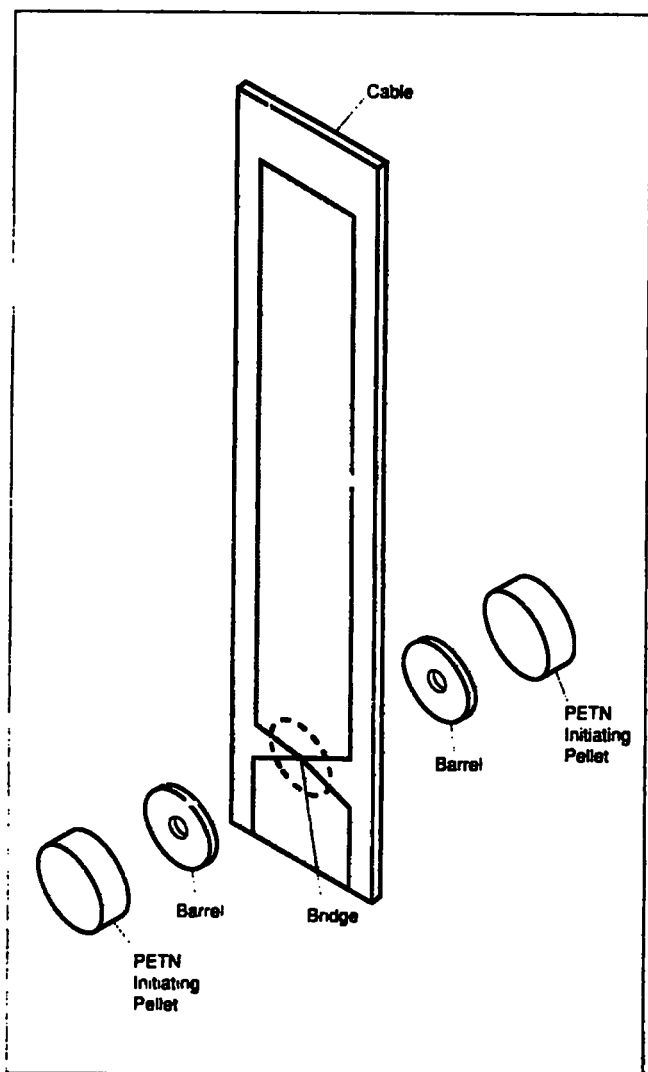

Fig. 3. Slapper detonator system components.

The assemblies were viewed on the rotating mirror camera, as shown in Fig. 4. The streak camera was focused on the mirror images so that the sides of the pellets appeared as blurred images in the photographic and dynamic records. Figure 5 is a set of film traces recorded in these tests.

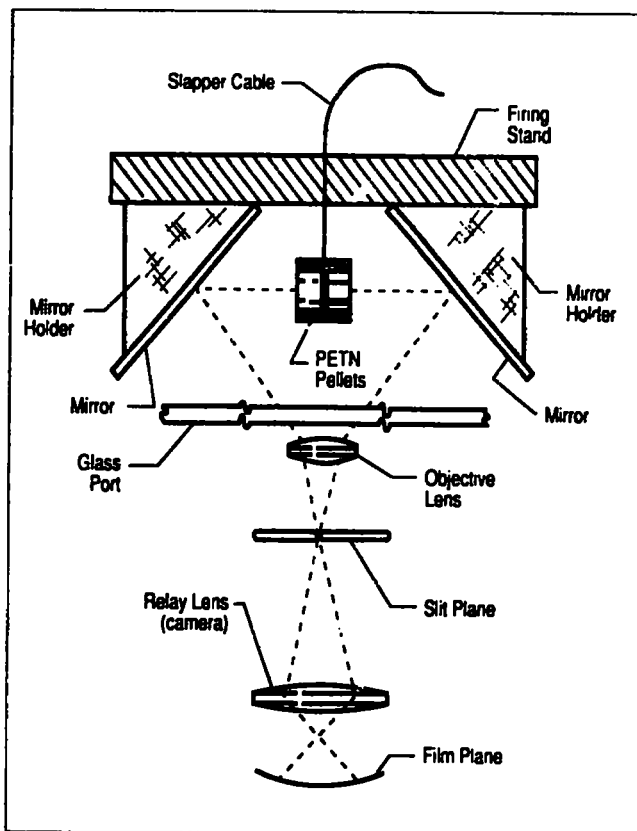

Fig. 4. Streak camera view of bidirectional assembly.



*Fig. 5. Film record of bidirectional slapper cable system with pellets only.*

Table I lists the results of the five threshold tests, for which a 2.0- $\mu\text{F}$  capacitively discharged unit (CDU) was used. After viewing the results of these first five tests, we fired twenty shots at 4000 V. Table II lists the test results from eight of these experiments.

**TABLE I  
TRANSIT TIME VS.  
FIRING VOLTAGE**

Firing Voltage (V)	Pellet 1, $t_s$ ( $\mu\text{s}$ )	Pellet 2, $t_s$ ( $\mu\text{s}$ )	Average $t_s$ ( $\mu\text{s}$ )	$\Delta t_s$
4000	1.098	1.105	1.102	0.007
3000	1.215	1.203	1.209	0.012
2500	1.377	1.363	1.370	0.014
2000	1.402	1.388	1.645	0.486
1500	<sup>a</sup> —	<sup>a</sup> —	<sup>a</sup> —	<sup>a</sup> —

<sup>a</sup> Pellets failed to detonate.

**TABLE II  
TRANSIT TIME  
AT SET VOLTAGE**

Firing Voltage (V)	Pellet 1, $t_s$ ( $\mu\text{s}$ )	Pellet 2, $t_s$ ( $\mu\text{s}$ )	Average $t_s$ ( $\mu\text{s}$ )	$\Delta t_s$
4000	1.125	1.135	1.130	0.010
4000	1.102	1.100	1.101	0.002
4000	1.100	1.116	1.108	0.016
4000	1.118	1.131	1.125	0.013
4000	1.092	1.077	1.084	0.015
4000	1.083	1.068	1.076	0.015
4000	1.122	1.134	1.128	0.012
4000	1.076	1.076	1.076	0.000

Notes:  $t_s$  = transit time through pellet (referenced to load ring signal).

$\Delta t_s$  = time difference between two pellets.

### B. ER-347 with Small High-Explosive Spheres

After determining that the bidirectional slapper system is capable of initiating two pellets with good timing, we fired small (~1.5-in.-diam), spherical, high-explosive (HE) assemblies to obtain a composite map of the break-out patterns. The components of these assemblies appear in Fig. 6. The 1.84-g/cm<sup>3</sup> PBX-9501 hemispheres were machined to accommodate the barrels, pellets, and slapper/cable assembly, which were then embedded in the HE. Figure 7 shows how the assembled components create a nearly perfect spherical assembly.

In this type of assembly, each detonation wave must spread in a hemispherical fashion. To achieve this configuration, the thickness of the initiating pellet is adjusted experimentally. We conducted several experiments using 12.5-mm-diameter pellets of various thicknesses. The assemblies were viewed on the rotating mirror camera. A six-objective image rotator and displacer lens was used as the optical technique for mapping the break-out pattern. This technique allowed us to view the object at six different angles.

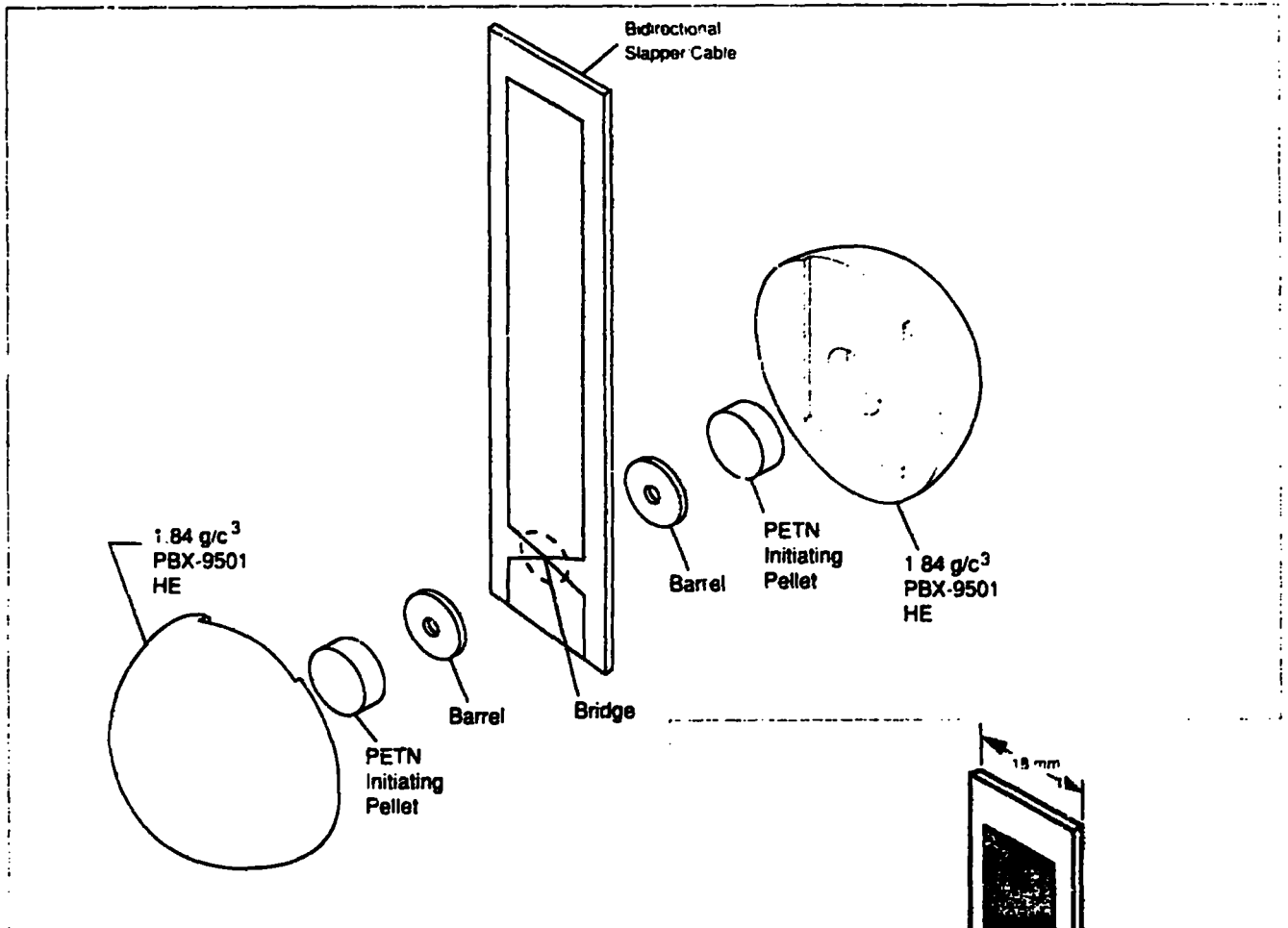

Fig. 6. Bidirectional slapper detonator system components.

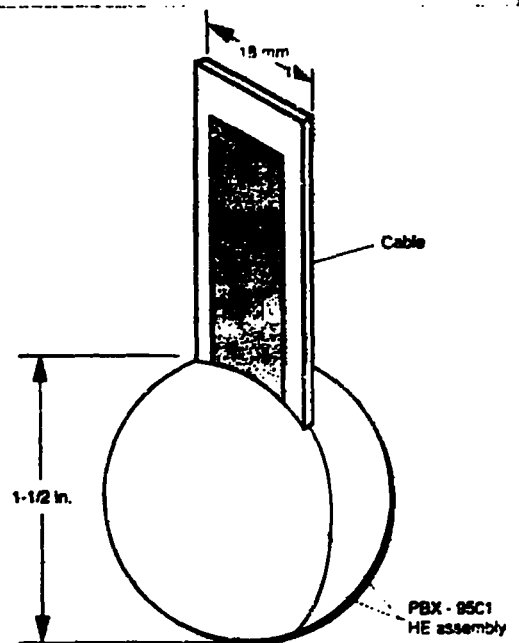
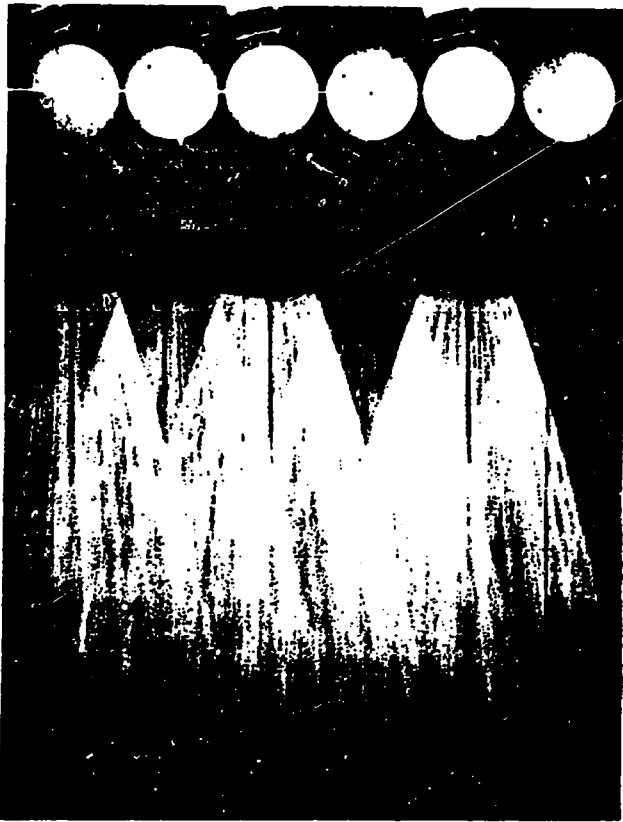
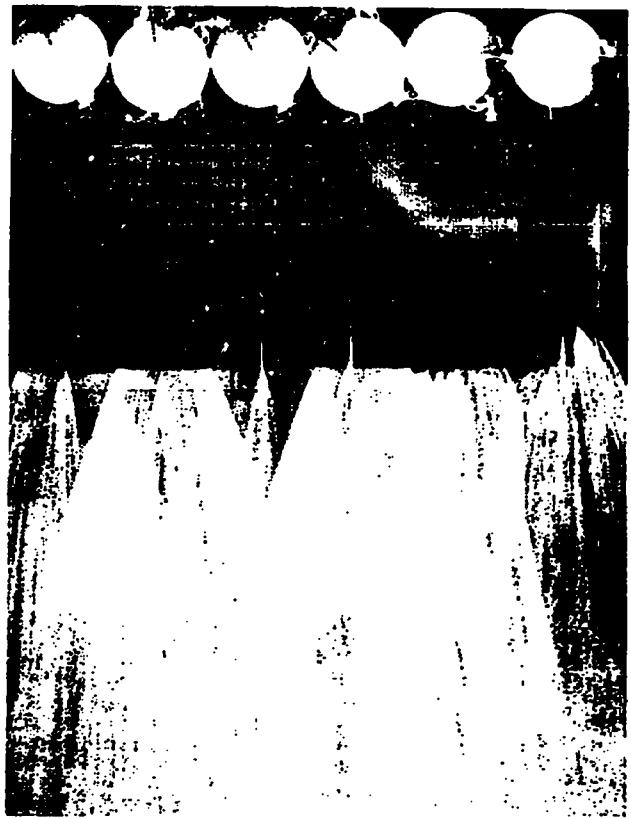

Fig. 7. Spherical detonation system.



*Fig. 8 (a). ER-347 with initiating pellets 5.72 mm thick.*



*Fig 8 (b). ER-347 with initiating pellets 4.10 mm thick.*

Figures 8(a-b) are film traces of the experiments. An ideal spherically expanding detonation wave produces perfectly flat traces. The traces in Fig. 8(a), from an experiment in which 5.72-mm-thick pellets were used, indicate that these pellets produced uneven waveforms, the center of the charge firing  $\sim 0.110 \mu\text{s}$  early. In Fig. 8(b) are film traces from an experiment in which 4.1-mm-thick PETN

pellets were used. We obtained the best results from this experiment. The traces are relatively flat, indicating that the detonation wave broke uniformly on all surfaces of the charge; therefore, we selected 4.1-mm pellets to be used in the 8-lb assemblies.



### C. RP-2 Detonator with Small High-Explosive Spheres

A part of our characterization work at LANL was to test RP-2-initiated spherical assemblies, like those used by AFWL, and to compare the results with those obtained from our tests of slapper-initiated systems. For comparison purposes and to determine whether the system might be improved, we conducted several experiments with the RP-2 system. Figure 9 shows the detonation system with the RP-2 detonator and a PBX-9407 pellet positioned at the equator of the PBX-9501 charge.

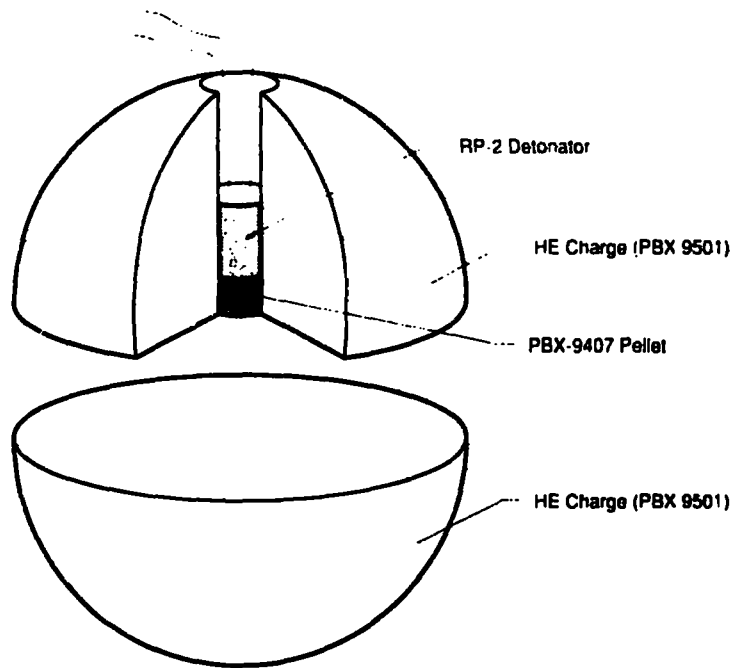

*Fig. 9. Spherical assembly with RP-2 detonator and PBX-9407 pellet.*

We viewed the tests with the streak camera, using the same optical technique as that used for the assemblies fired with the slapper system. Figures 10(a-d) are film traces of these experiments. The results shown in Fig. 10(a) are from an experiment in which the RP-2 detonator was positioned precisely at the equator of the HE. The traces from this test are very uneven, showing that the solid hemisphere fired  $\sim 0.700 \mu\text{s}$  earlier than did the hemisphere containing the RP-2 detonator. These results suggested that we might obtain a more spherical break-out if the RP-2 detonator were backed off slightly.

In the next test, the RP-2 was placed 2.0 mm from the equator, and a 2-mm-thick PBX-9407 pellet was used to fill the space created by moving the detonator. The film traces from this experiment, shown in Fig. 10(b), indicate a slight improvement; however, the break-out pattern remains quite asymmetrical, indicating that the solid hemispherical assembly was still firing  $\sim 0.400 \mu\text{s}$  early. The traces in Fig. 10(c) are from a test in which a 4-mm-thick pellet was used. Note that the break-out pattern becomes more uneven as the RP-2 detonator is backed off farther from the equatorial position. An additional experiment was conducted with a PBX-9407 pellet located in each hemisphere. Test results, shown in Fig. 10(d), indicate that this configuration does not improve the symmetry of the detonation waveform.

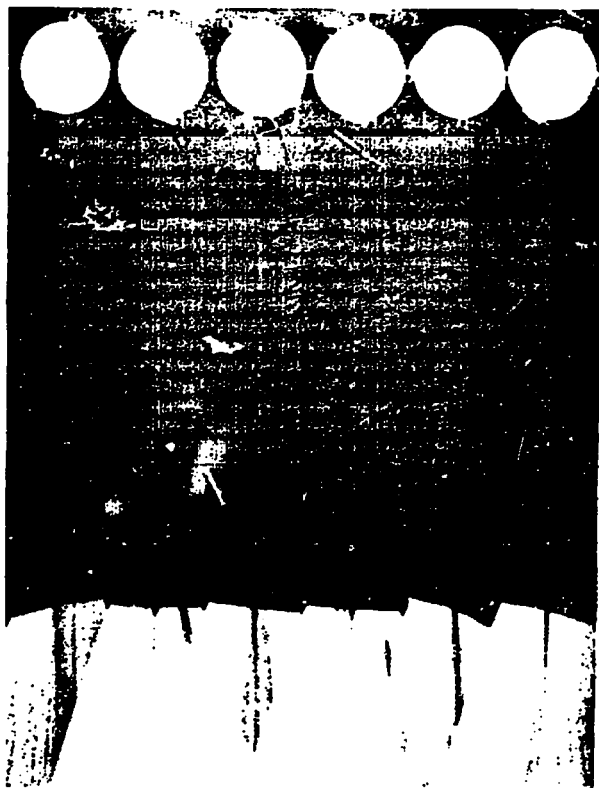

*Fig 10 (a) RP-2 detonator only*

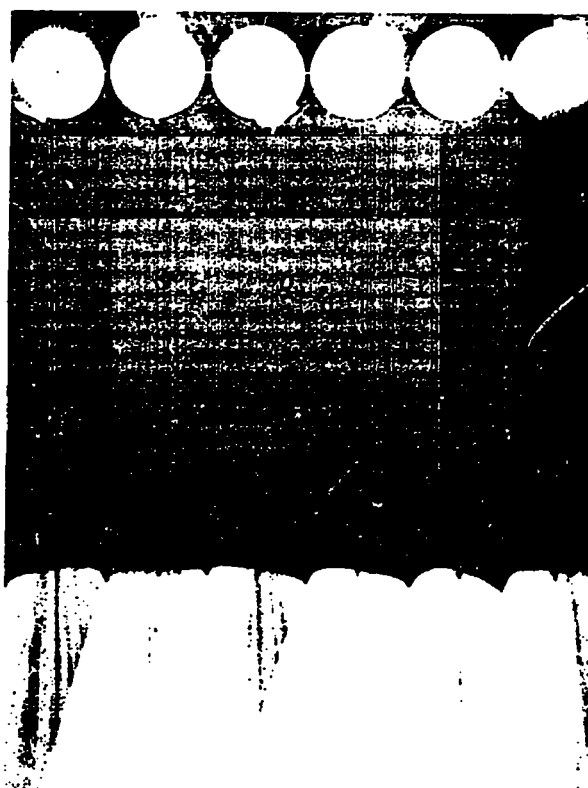

*Fig 10 (b) RP-2 detonator with 2-mm-thick PBX-9407 pellet*



*Fig 10 (c) RP-2 detonator with 4-mm-thick PBX-9407 pellet*

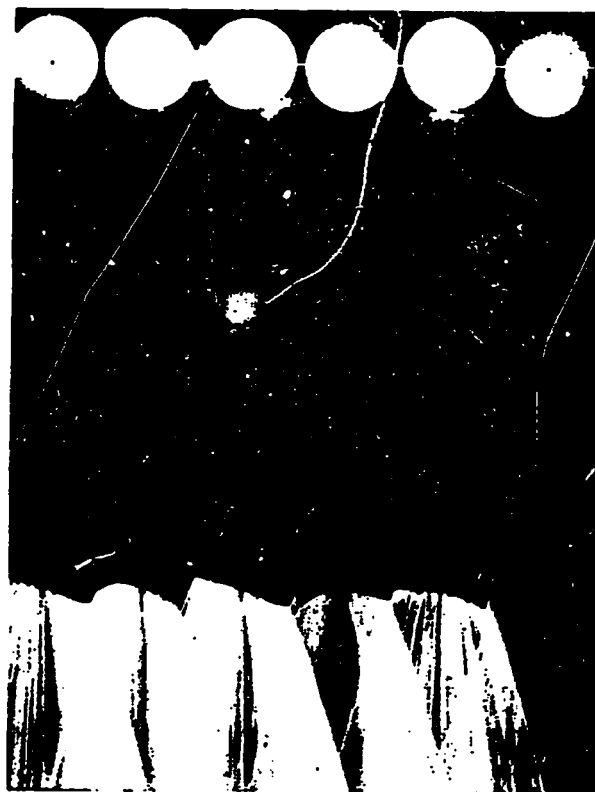

*Fig 10 (d) RP-2 detonator with two 2-mm-thick PBX-9407 pellets.*

## V. TESTS OF 8-LB SPHERICAL ASSEMBLIES

We test-fired 8-lb assemblies like those to be fired at DRI in order to map and compare the break-out patterns produced by slapper systems and RP-2 detonators. Figure 11 shows how the streak camera viewed these experiments. The streak camera is focused on the mirror images. The assembly is immersed in water, to aid in the quenching of light and to prevent overwriting in the dynamic film record.

Overall, the test results for the 8-lb assemblies were identical to those obtained with the small assemblies. In Fig. 12 are film traces of the experiment in which we used the bidirectional slapper cable. As the flat traces shown in Fig. 12 indicate, we obtained the best results from this experiment.

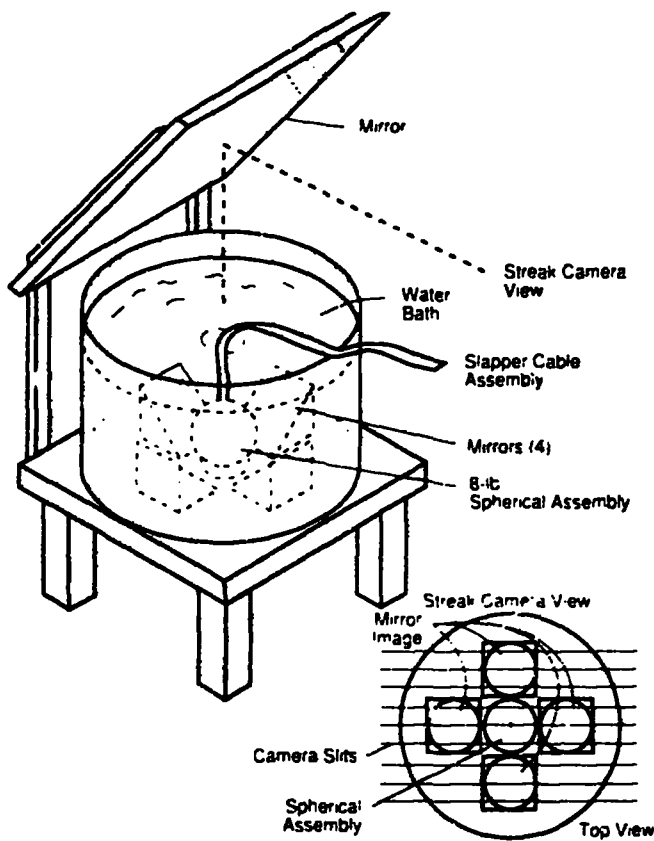

Fig. 11. Experimental setup for 8-lb spherical assembly.

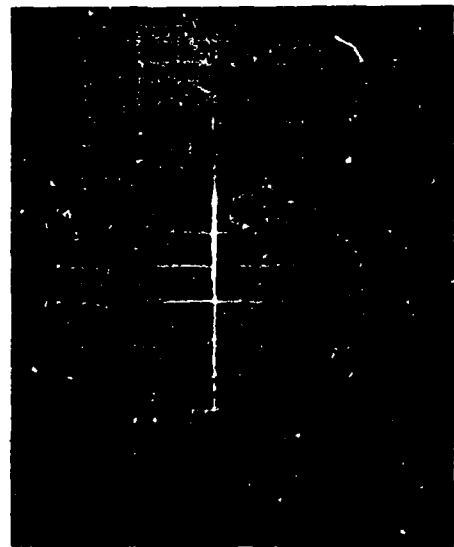
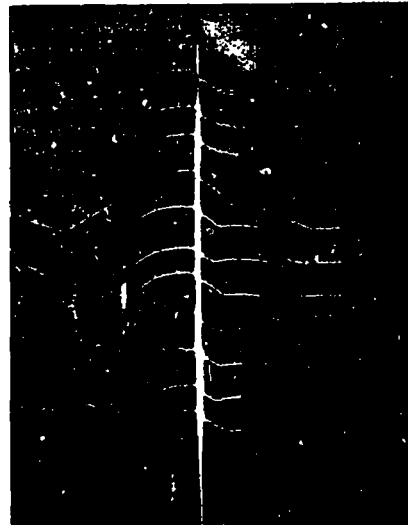

Fig. 12. 8-lb assembly with slapper cable system.

In the other two experiments we used the RP-2 firing mode. The detonator was embedded in the HE charge in a manner similar to that used for the smaller assemblies. The streak camera setup for these tests was like that described for the test of the slapper assembly. The film traces in Fig. 13 are from the first experiment, in which the RP-2 detonator was placed directly at the equator of the assembly. Test results indicate that the solid hemisphere fired early. In the second experiment, the RP-2 detonator was located 2.0 mm from the center of the sphere, and a PBX-9407 pellet was used to fill the space created by moving the detonator. Figure 14 shows film traces of that experiment. Results indicate that this arrangement had a reverse effect on the system: the solid hemispherical assembly fired later than the half containing the RP-2 detonator. We therefore conclude that moving the center of initiation does not improve the expanding symmetry of this type of system.



*Fig. 13. 8-lb assembly with RP-2 detonator only.*

*Fig. 14. 8-lb assembly with RP-2 detonator and 2-mm-thick PBX-9407 pellet.*

Three 8-lb assemblies with ER-347 slapper cables were shipped to DRI. As part of our work, we also supplied a special fireset, designated TSD-34, with each of the 8-lb assemblies. Because of the proximity of the fireset to the HE charge, the fireset on each test was destroyed. Along with the firesets, we sent all the equipment (cabling control unit and spare connectors) required for the DRI tests. When the assemblies were fired at DRI, test results showed the spherical initiation to be very symmetrical.

## VI. CONCLUSIONS

We have demonstrated that the ER-347 bidirectional slapper system initiates pellets in both directions with excellent time correlation and produces a perfectly sym-

metrical expanding shock wave. We have also shown that the RP-2 detonator system does not produce a symmetrical explosion and that moving the center of initiation away from the equatorial center does not improve the symmetry. Therefore, we conclude that the slapper system is the more effective means of producing a spherically expanding shock wave.

## ACKNOWLEDGEMENTS

We thank W. H. Meyers for his support and helpful discussions, R. Fresquez and M. Naranjo for fabricating the slapper circuits, Rose Gallegos and Margaret Richardson for their skillful assistance with the experiments, and Chris Quihuis for designing and fabricating the firesets.